

# INSERTA TEE SPECIFICATIONS

## FATBOY, SDR26 & SDR35 GASKETED BELL GRAVITY APPLICATIONS

- A.** Bell end accepts pipe with SDR26, SDR35 and ASTM D3034 or equivalent O.D. specification in 4" and 6" sizes
- B.** Curvature varies with mainline diameters
- C.** Spigot end SDR26, PVC SDR35 and ASTM D3034  
Diameters: 4" and 6"

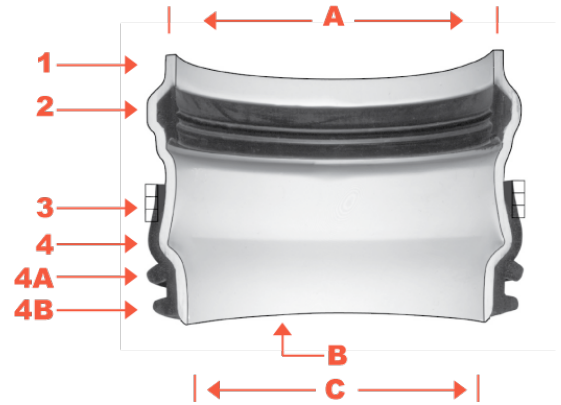

PART	PART NAME
1	Hub adaptor
2	Rubber Gasket
3	Securing Clamp*
4	Rubber Sleeve (available in Nitrile and EPDM by special order)
4A	Upper Segment**
4B	Lower Segment***

**MATERIALS**  
PVC SDR26 ASTM D3034  
ASTM F477  
Band SS #301  
Screw SS #305  
Housing SS #301  
ASTM F477

\* Optional: #316 Stainless Steel band, screw and housing  
\*\*Distance between 4A and 4B will vary by product type  
\*\*\*Will not appear on rubber sleeves for concrete or clay pipe

INSERTA TEE SIZE	HOLE DIAMETER
4" (100 mm)	4 1/2" (114 mm)
6" (150 mm)	6 1/2" (165 mm)

NOTE: Recommended method of cutting hole is with hole saw for PVC and other plastics, and diamond bit for concretes, clay, FRP and D.I. (See installation instructions. Hole saws are available for purchase or rent.)

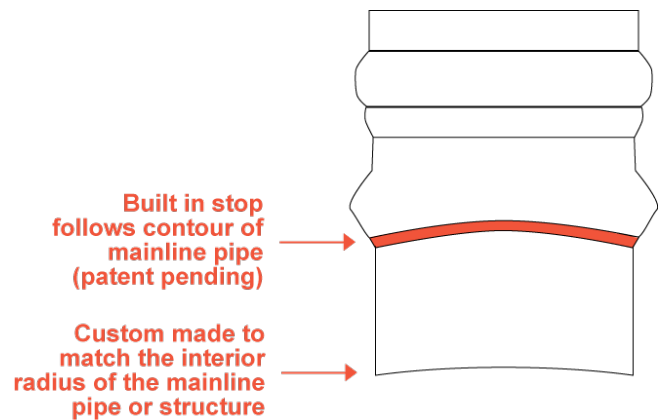

Project Name:	Lateral Size:
Type of Mainline Pipe or Structure:	Mainline Size: